



1 lockers



2 shelving

All Probe products are available from a wide network of authorised Probe dealers



3 cupboards & work stations



4 kinetic mobile shelving



5 technic shelving



6 cloakroom



7 cabinets



8 ultrabox plastic lockers



MADE IN THE UK



MEETS BS 4680:1996



PROBE

ULTRABOX[®]
PLASTIC LOCKERS



1 2 3 4 5 6 7 8 9

CHALLENGING ENVIRONMENTS

ULTRABOX®

STYLE, INDOORS OR OUTSIDE*

*If sheltered from direct rain



www.richardsonsuks.co.uk | TEL: 01642 242228



www.probe-manufacture.co.uk

ULTRABOX PLUS⁺

PERFORMS IN THE MOST CHALLENGING ENVIRONMENTS

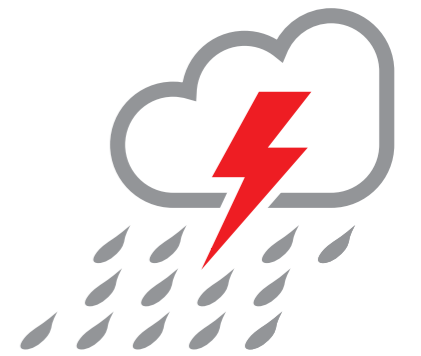

SEAL OUT THE WEATHER

WATERPROOF SEAL, PLUG AND LOCK GASKET MAKES THE ULTRABOX PLUS FULLY WATERPROOF†

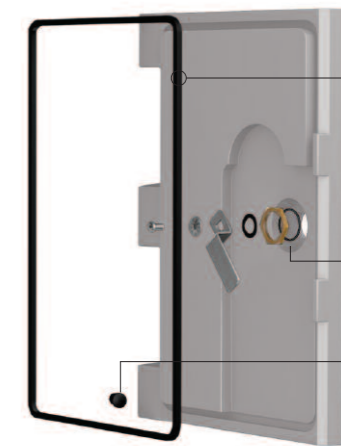

WATERPROOF DOOR SEAL

WATERPROOF LOCK GASKET

WATERPROOF DRAIN HOLE PLUG

SUITABLE FOR THE MOST CHALLENGING ENVIRONMENTS AND ALL WEATHER CONDITIONS



†We recommend the use of weather resistant or waterproof locks

CHALLENGING ENVIRONMENTS

ACTIVECOAT® anti-bacterial technology **hygienic, hard wearing and anti-bacterial**
99.9% REDUCTION OF BACTERIA INCLUDING MRSA & E-COLI for the life of the coating

- ▶ CORROSION PROOF
- ▶ VANDAL RESISTANT
- ▶ HIGHLY WATER RESISTANT
- ▶ NO ON-SITE ASSEMBLY
- ▶ 10 YEAR GUARANTEE**
- ▶ GRAFFITI PROOF



ULTRABOX® CHALLENGING ENVIRONMENTS
PLASTIC LOCKERS



www.richardsonsuk.co.uk | TEL: 01642 242228



www.probe-manufacture.co.uk

NO ASSEMBLY REQUIRED



**Terms and conditions apply, see www.probe-manufacture.co.uk for details.

- ▶ NO ON-SITE ASSEMBLY
- ▶ VANDAL RESISTANT
- ▶ RUST PROOF

- ▶ 10 YEAR GUARANTEE^{††}
- ▶ WATERPROOF*
- ▶ ANTI-BACTERIAL
- ▶ ONE PIECE DESIGN FOR A NEATER FINISH AND SPEEDY INSTALLATION

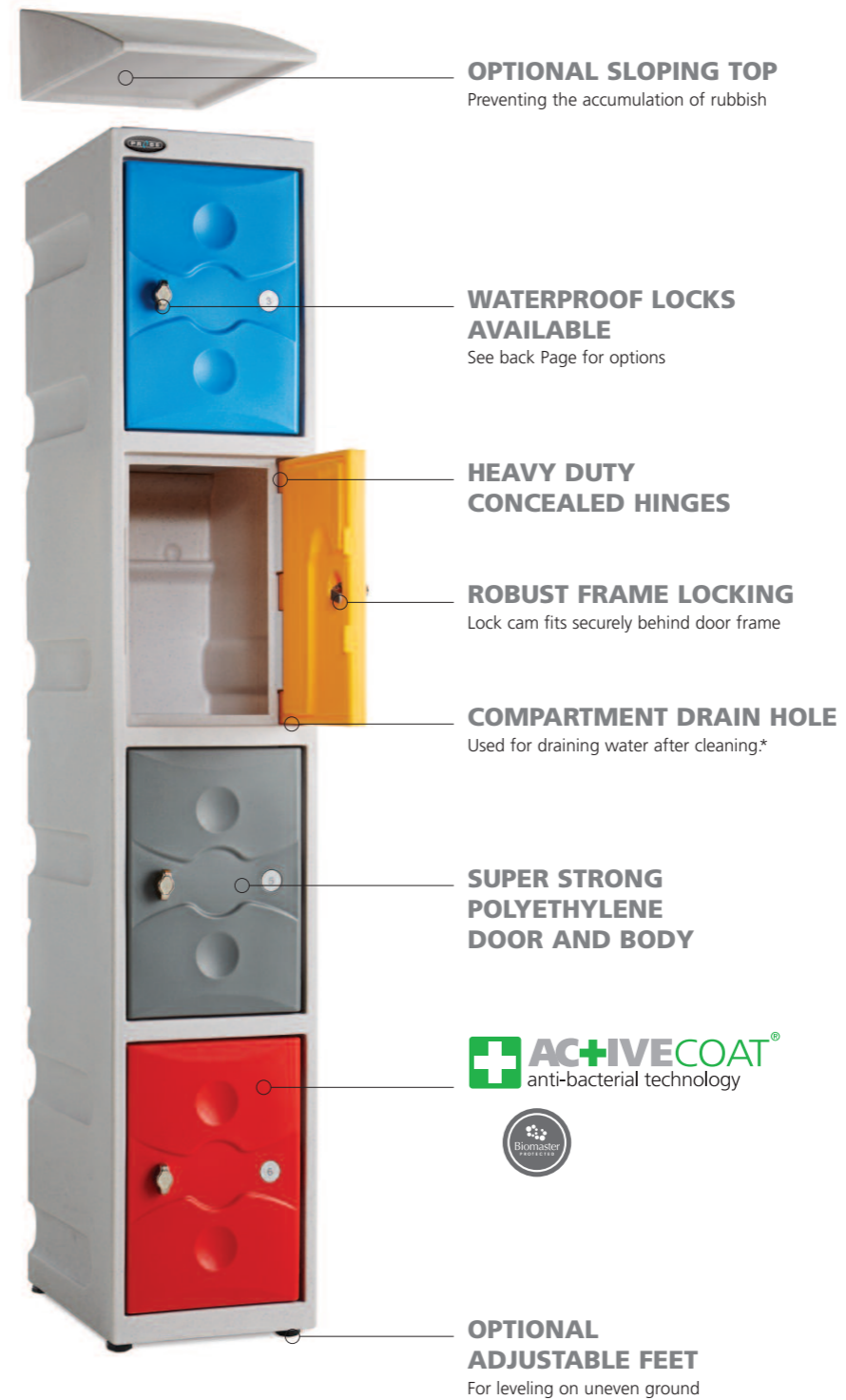

OPTIONAL WATERPROOF SEAL MAKES THE ULTRABOX PLUS FULLY WATERPROOF



HEAVY DUTY, VANDAL PROOF CONCEALED HINGES



COMPARTMENT DRAIN HOLE SITS NEATLY OUT OF SIGHT BEHIND THE DOOR*



AFTER WASHING THE LOCKER THE SLOPING SHELF DIRECTS WATER TO THE DRAIN HOLE
Drain hole is sealed on Ultrabox plus

*The drain hole is sealed on the Ultrabox Plus version

AVAILABLE COLOURS FOR ULTRABOX LOCKERS

DOOR COLOUR



BODY COLOUR



www.richardsonsuks.co.uk | TEL: 01642 242228



www.probe-manufacture.co.uk

CHALLENGING ENVIRONMENTS

ACTIVECOAT[®] anti-bacterial technology **hygienic, hard wearing and anti-bacterial**
99.9% REDUCTION OF BACTERIA INCLUDING MRSA & E-COLI for the life of the coating

^{††}Terms and conditions apply, see www.probe-manufacture.co.uk for details.

ULTRABOX®

STYLE, INDOORS OR OUT*

*If sheltered from direct rain



ULTRABOX PLUS⁺

PERFORMS IN THE MOST CHALLENGING ENVIRONMENTS

SUITABLE FOR EXTREME ENVIRONMENTS AND ALL WEATHER CONDITIONS

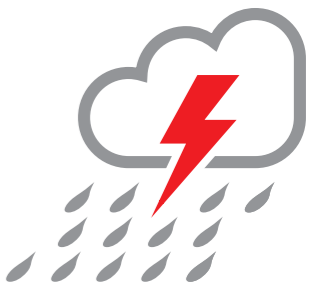

NESTING

Pre formed markers allow for easy drilling and bolting when nesting is required. Rubber gasket ensures a secure and water proof connection between lockers.

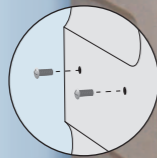
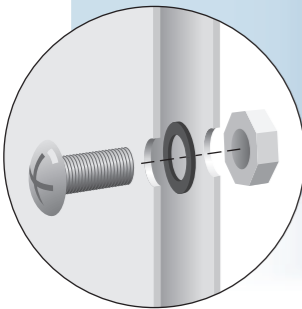

A RANGE OF LOCKS SHOWN HERE FOR ILLUSTRATION PURPOSES SEE BACK PAGE FOR FULL RANGE



www.richardsonsuks.co.uk | TEL: 01642 242228



www.probe-manufacture.co.uk

CHALLENGING ENVIRONMENTS



ACTIVECOAT® hygienic, hard wearing and anti-bacterial
anti-bacterial technology 99.9% REDUCTION OF BACTERIA INCLUDING MRSA & E-COLI for the life of the coating

††Terms and conditions apply, see www.probe-manufacture.co.uk for details.

FULLY WATERPROOF



TYPE 2*

WATERPROOF HASP & STAPLE*
This design allows easy padlock fitting. Shank diameter min 5mm - max 7mm. Padlock sold separately.

○ **WATERPROOF**

*This lock is included in locker price. Request lock type at time of ordering.



TYPE 3

WATERPROOF CAM LOCK

This is a Waterproof Chlorine resistant high quality 7 pin tumbler system with a nickel silver key. Its all brass construction lends itself for use in harsh environments such as swimming pools.



Two keys are included with each standard lock.

- **WATERPROOF**
- **CHLORINE RESISTANT**



TYPE 6

DIGITAL COMBINATION LOCK 40,000 COMBINATIONS

- **WATERPROOF**
- **CHLORINE RESISTANT**
- Simple to program
- Batteries last up to 50,000 operations
- Single user supplied as standard
- Multi user option available (specify when ordering)



TYPE 8

WATERPROOF COIN/TOKEN - RETURN/RETAIN

These Waterproof and Chlorine resistant locks are available with coin denominations £/€ or tokens, for either return or retain.

- **WATERPROOF**
- **CHLORINE RESISTANT**



OPTIONAL ADJUSTABLE FEET FOR UNEVEN FLOORS



OPTIONAL SLOPING TOP PREVENTING THE ACCUMULATION OF RUBBISH

Sloping top increases the locker height by 150mm



OPTIONAL WATERPROOF SEAL MAKES THE ULTRABOX PLUS LOCKER FULLY WATERPROOF



WEATHER RESISTANT



TYPE 1*

WATER RESISTANT CAM LOCK*

Micro sprung 10 disc lock incorporating spring loaded weather shield. This lock features a massive 3000 serial combinations all exclusive to Probe.



Two keys are included with each standard lock.

- **WEATHER RESISTANT**

*This lock is included in locker price. Request lock type at time of ordering.



TYPE 5

RE-ENGINEERED RE-PROGRAMMABLE COMBINATION LOCK

Reprogrammable Combination Lock, tough Zinc Alloy housing and dials with 10,000 possible combinations. Lost codes reset with key, sold separately. Suitable for multi user applications.

- **WEATHER RESISTANT**

WATER PROOF

Suitable for the most challenging environments and all weather conditions

WEATHER RESISTANT

Suitable for indoors or out if sheltered from direct rain

NO WEATHER PROTECTION

For internal use where not exposed to water or chlorine

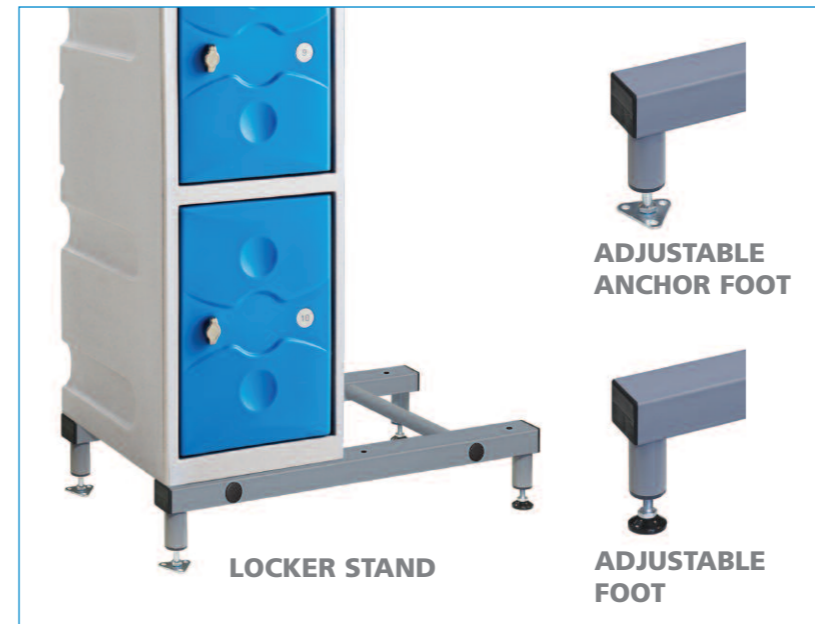

LOCKER STAND

ADJUSTABLE ANCHOR FOOT

ADJUSTABLE FOOT

DRAIN HOLE SITS NEATLY OUT OF SIGHT BEHIND THE DOOR ALLOWING THE INSIDE TO BE JET WASHED AND THE WATER TO DRAIN

Drain hole is sealed on Ultrabox plus



SLOPING SHELF ALLOWS JET WASH WATER TO DRAIN TOWARDS THE DRAIN HOLE

Drain hole is sealed on Ultrabox plus



DOUBLE COAT HOOK FITTED IN ALL TWO DOOR LOCKERS



NO WEATHER PROTECTION



TYPE 4

RE-PROGRAMMABLE COMBINATION LOCK

Re-programming using service key
Easy to use front facing dial with 10,000 combinations. One Service Key required per installation. Service Key sold separately. Not recommended for multi user applications.



TYPE 7

DIGITAL COMBINATION LOCK 40,000 COMBINATIONS

- Simple to program
- Batteries last up to 50,000 operations
- Single user supplied as standard
- Multi user option available (specify when ordering)
- Emergency access using service key



TYPE 9

BeCode Air+ RFID Technology

The BeCode Air+ only has to be 'shown the card' (or matching transponder) to operate. No external programming devices needed. 10,000 closings with one battery. It doesn't get any simpler.

